

1500 Data Sheet



SERIES: 1000 WOOD GRILLES

STYLE: 1500 BAFFLE

Overview

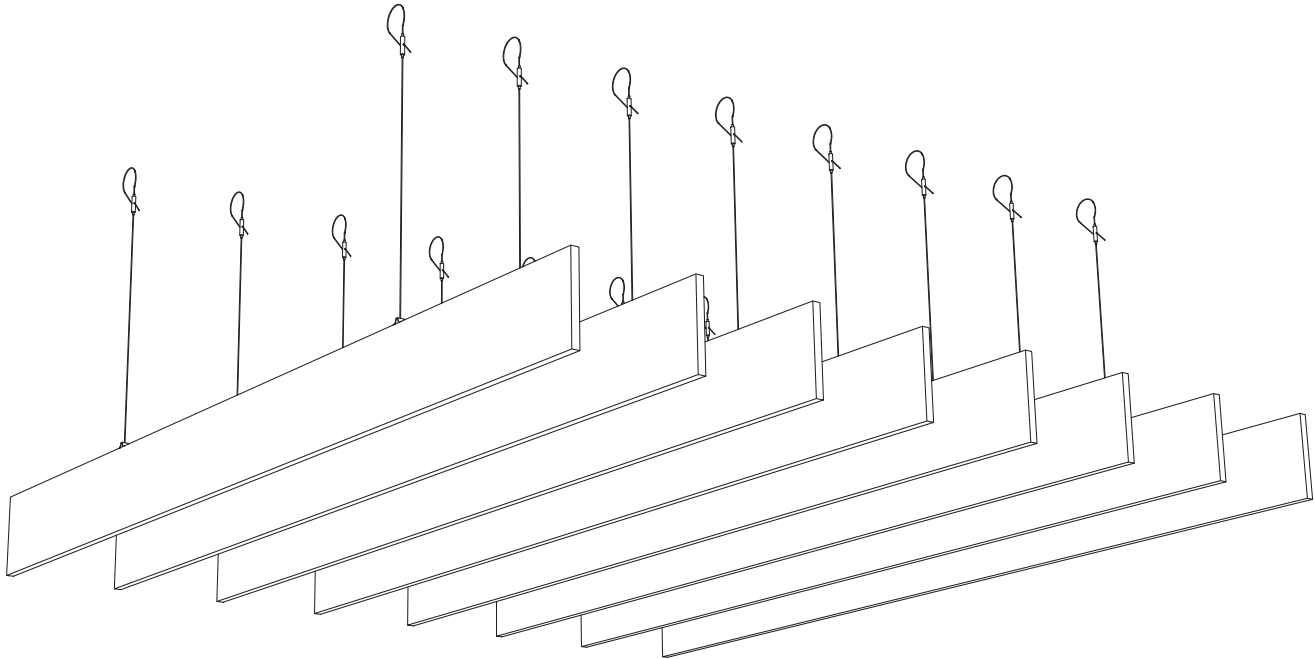

The **9Wood Baffle** offers the visual definition of large, vertically-oriented members free of t-bar, backers, or other cross-members. Independently-suspended via aircraft-cable, Baffles are used for clouds or for cover in larger areas. Architectural veneers laminated to Class A substrate provide added dimensional stability over solid wood.

Baffles come in standard lengths of 8' and 10', with one standard width 1-7/16".

Attachment for the 9Wood Baffle is via adjustable 24" aircraft-cables threaded into baffle clips (Longer cable lengths available with added lead-time and cost). Biscuit clips at abutting ends provide a clean joint where longer runs are desired.

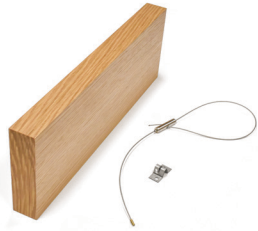

1500 Data Sheet



SERIES: 1000 WOOD GRILLES

STYLE: 1500 BAFFLE

Product Data

Application

The 9Wood Baffle uses a pre-fabricated, veneered member with factory-attached clips for field-attachment of 9Wood aircraft cable. Baffles are attached via aircraft cable and hex-plug, which is inserted into baffle clips. Aircraft cable is adjustable via a pre-attached cable gripper. Baffles are suspended with a max span of 4' between baffle clips in order to support weight of members. Factory-provided locking biscuit clips snap in place to allow for wood movement across longer span.

Acclimatization

Baffles must be cared for in a controlled interior environment (RH 25%-55% max; temp. 60°-80°) and installed only after reaching equilibrium moisture content. Should the building fall outside these limits consult 9Wood, Inc. for our 3 Tests/3 Tracks Acclimatization Advisory.

Acoustics

Baffles provide limited diffusion however, acoustics can be enhanced via sound absorbing material, such as insulation, batts, or acoustical ceiling tile (ACT), specified for the desired areas.

Fire Rating

Individual members consist of veneered particleboard that is composed of a Fire Rated formula.

LEED

Baffles may qualify toward MR-3, MR-4.1/4.2, MR-5.1/5.2, MR-6, MR-7, IEQ-4.2 or IEQ-4.4. As all products are custom-fabricated, LEED credit opportunities are project by project. Please contact 9Wood, Inc. for specifics.

MEP

Baffles permits MEP penetrations in the ceiling surface. Cut members may require supplemental reinforcement. Fixtures and diffusers must be independently supported.

Seismic

Please consult local code or a licensed engineer for any additional requirements.

Species & Finishes

9Wood can offer both domestic and imported veneer species for Baffles. Clear, matte sheen finish is standard; custom color matches and opaque finishes are available.

Suspension

Baffles are attached to the structural element via aircraft cable with factory-attached hex plugs and baffle clips. Cables come in standard 24" lengths. Longer lengths available with added lead-time and cost.

System Weight

Baffles typically weigh 2-6 pounds per linear foot, depending on thickness and depth of the baffle member.

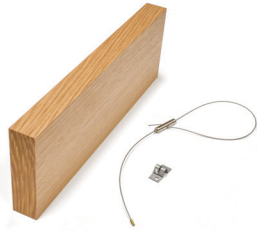

1500 Data Sheet



SERIES: 1000 WOOD GRILLES

STYLE: 1500 BAFFLE

Typical Specifications

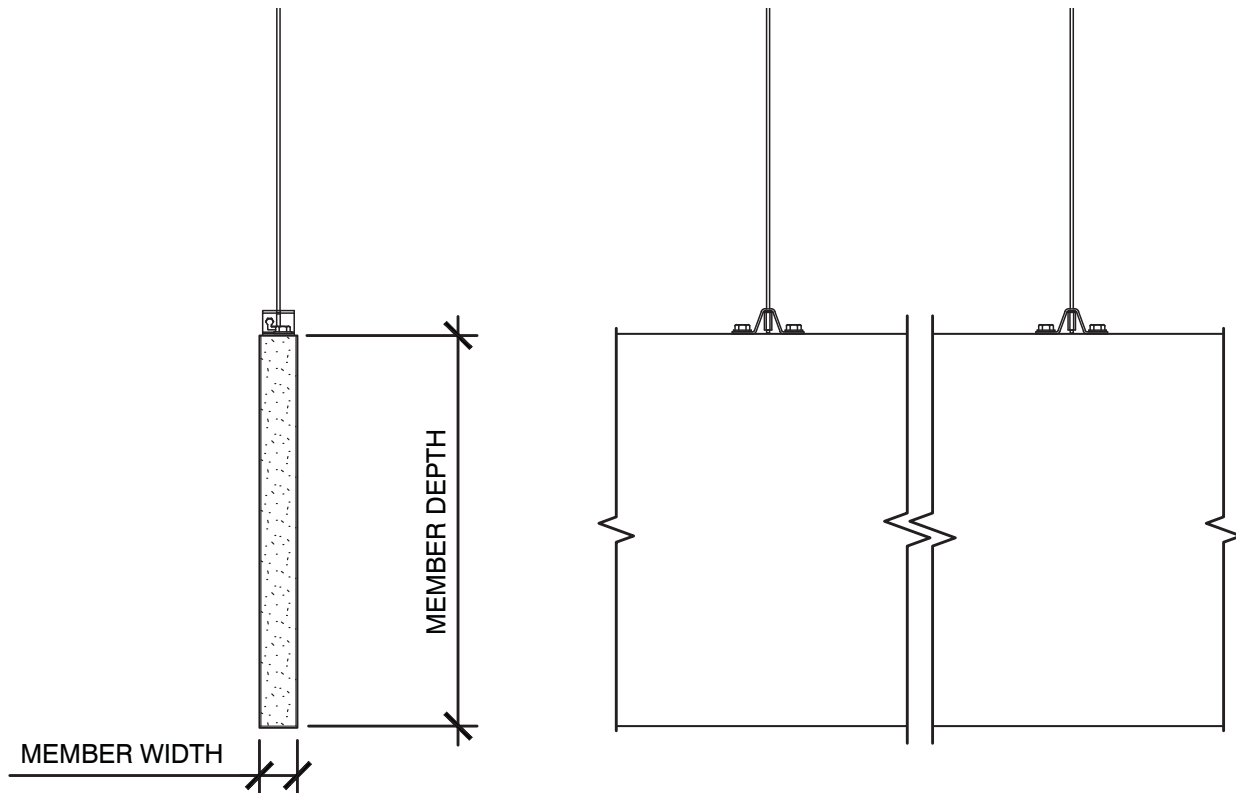

SKU Table

Width	Depth		
	5-3/4"	7-3/4"	11-3/4"
1-7/16"	1526-1	1528-1	15212-1

Please see 9Wood.com for information on appropriate species selections

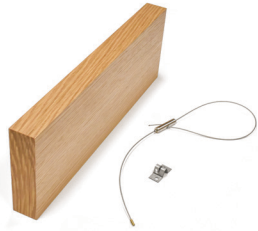

1500 Data Sheet



SERIES: 1000 WOOD GRILLES

STYLE: 1500 BAFFLE

Perimeter Conditions and Suspension

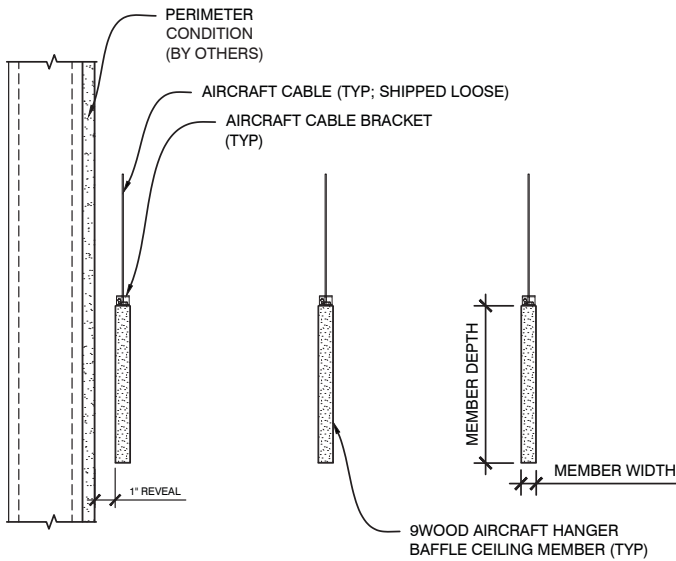

PERIMETER CONDITION (FRONT)

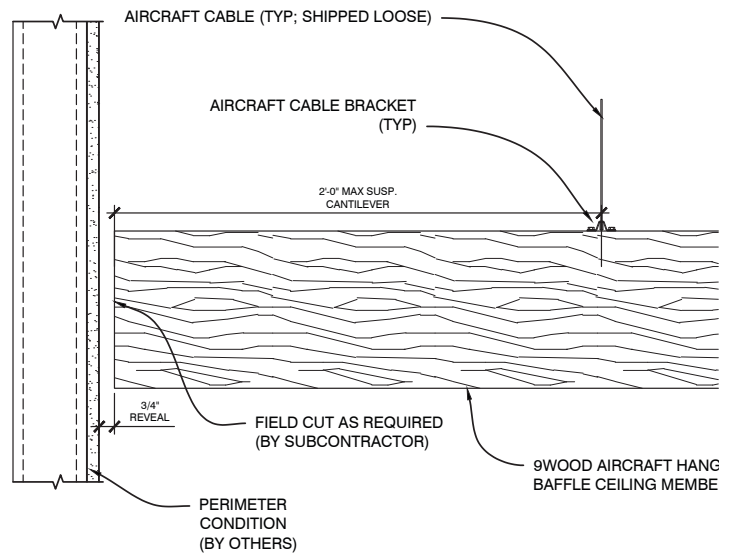

PERIMETER CONDITION (SIDE)

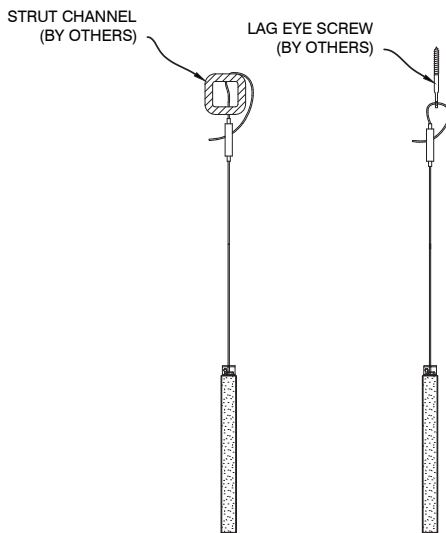

SUSPENSION DETAILS

BISCUITING WILL BE REQUIRED AT ABUTTING BAFFLES; BISCUIT PROFILING DONE BY 9WOOD, BISCUITS SENT LOOSE FOR IN-FIELD INSTALLATION

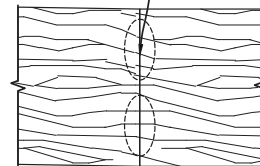

JOINT CONDITION