



4500 Data Sheet



SERIES: 4000 WOOD TILES

STYLE: 4500 XL CHANNEL TILE

Overview

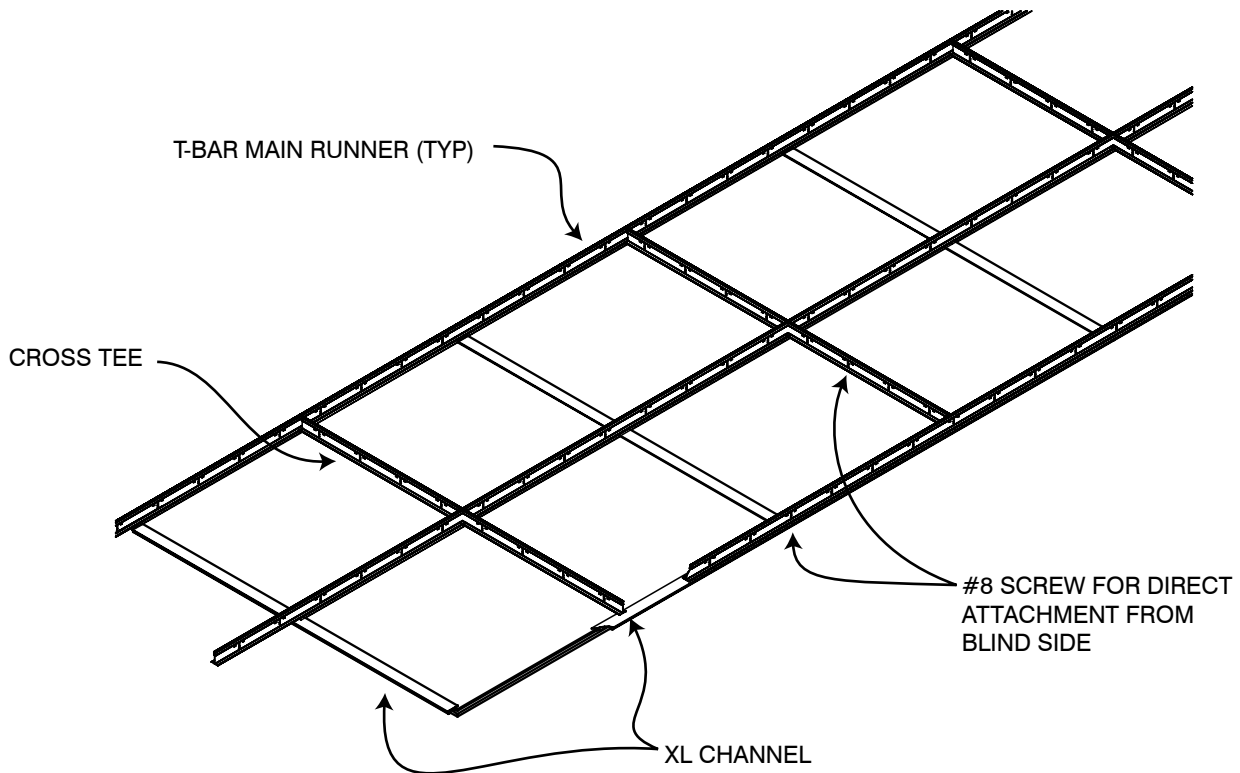

Designed with large wood panels in mind, the **4500 XL Channel Channel Tile** wood ceiling offers a floating tiled appearance. The 4500 style installs progressively using perimeter extrusion clips (XL Channel). The reveal between panels are 3/8" wide.

Attachment for the XL Channel Tile is via a profiled edge that fits into the 9Wood XL Channel.



4500 Data Sheet



SERIES: 4000 WOOD TILES

STYLE: 4500 XL CHANNEL TILE

Product Data

Application

The XL Channel Tile provides large panel suspension while maintaining a floating tiled look with concealed suspension using real wood veneers on fire rated cores. Access can be achieved through strategically located access panels or from ceiling perimeters. XL Channel is seismically compliant. Tiles may be perforated (see series 5000 Perforated Wood Tiles).

Performance

Acclimatization

XL Channel Tiles must be cared for in a controlled interior environment (RH 25%-55% max; temp. 60°-80°) and installed only after reaching equilibrium moisture content. Should the building fall outside these limits consult 9Wood for our 3 Tests/3 Tracks Acclimatization Advisory.

Acoustics

The XL Channel Tile is considered acoustically reflective unless perforated.

Fire Rating

Individual members and components can be treated with Class I (A) Fire Retardant chemicals (veneered particleboard use FR formulas). Particular species or styles have not been tested.

LEED

XL Channel Tiles may qualify toward MR-3, MR-4.1/4.2, MR-5.1/5.2, MR-6, MR-7, IEQ-4.2 or IEQ-4.4. As all products are custom-fabricated, LEED credit opportunities are project by project. Please contact 9Wood for specifics.

MEP

The XL Channel Tile permits MEP penetrations in the ceiling's surface. Cut tiles may require supplemental reinforcement. Fixtures and diffusers must be independently supported.

Seismic

XL Channel tiles provide seismic code compliance by means of mechanical direct screw attachment to T-Bar grid via the XL Channel extrusion. Consult local code for any additional requirements or a licensed engineer.

Species & Finishes

9Wood can offer both domestic and imported species for the XL Channel Tile. Clear, matte sheen finish is standard; custom color matches and opaque finishes are available.

Suspension

XL Channel Tiles are suspended from 15/16" heavy duty T-Bar main runners. Main runners are installed 2' on center, depending on tile weight.

System Weight

XL Channel Tiles typically weigh 3 pounds per square foot.



4500 Data Sheet



SERIES: 4000 WOOD TILES

STYLE: 4500 XL CHANNEL TILE

Typical Specifications

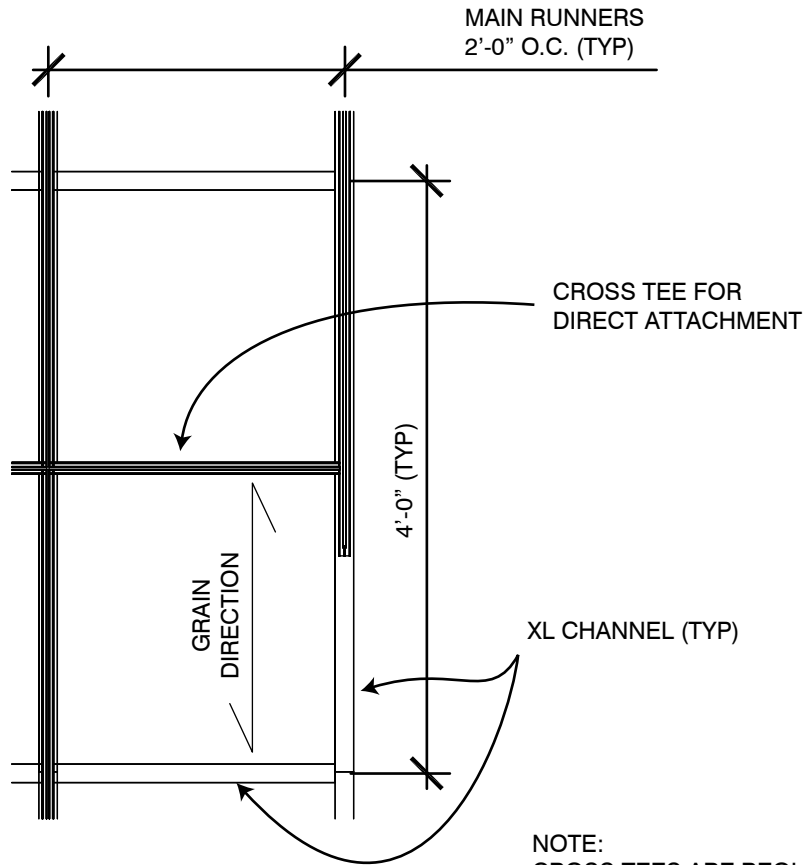

NOTE:
CROSS TEES ARE REQUIRED FOR DIRECT
ATTACHMENT OF WOOD TILES FROM BLIND SIDE

SKU Table

Tile Width	Tile Length (Parallel to Grain Direction)						
	24"	36"	48"	60"	72"	84"	96"
24"			4524-48	4524-60	4524-72	4524-84	4524-96
36"		4536-36	4536-48	4536-60	4536-72	4536-84	4536-96
48"	4548-24	4548-36	4548-48	4548-60	4548-72	4548-84	4548-96

Additional width, depth, and M/LF options may be available. Please check with 9Wood if you don't see the combination that you have in mind.



4500 Data Sheet



SERIES: 4000 WOOD TILES

STYLE: 4500 XL CHANNEL TILE

Perimeter Conditions and Suspension

